

Technical sheet :

MT 1335 ST5



Capacities		Metric
Max. capacity	Q	3500 kg
Max. lifting height	h3	12.55 m
Max. Reach	l4	8.75 m
Breakout force with bucket		6082 daN
Weight and dimensions		
Overall length to carriage	l11	5.86 m
Overall width	b1	2.28 m
Overall height	h17	2.42 m
Wheelbase	y	2.88 mm
Ground clearance	m4	0.42 m
Overall cab width	b4	0.88 m
Tilt-up angle	a4	12 °
Tilt-down angle	a5	114 °
External turning radius (over tyres)	Wa1	3.84 m
Unladen weight (with forks)		9050 kg
Tyres type		Pneumatic
Standard tyres		Alliance 400/80 - 24 - 162A8
Forks length / width / section	l / e / s	1200 mm x 1040 mm / 45 mm
Performances		
Lifting		10.4 s
Lowering		8.6 s
Extension		15.5 s
Retraction		11.5 s
Crowd		5 s
Dump		4 s
Engine		
Engine brand		Deutz
Engine norm		Stage V
Engine model		TCD 3.6
Number of cylinders / Capacity of cylinders		4 - 3621 cm³
I.C. Engine power rating - Power (kW)		100 Hp / 75 kW
Max. torque / Engine rotation		410 Nm/m @ 1600 tr/min
Drawbar pull (Laden)		7660 daN
Transmission		
Transmission type		Torque Converter
Number of gears (forward / reverse)		4 / 4
Max. travel speed		24.9 km/h
Parking brake		Automatic parking brake
Service brake		Oil-immersed multi-discs braking on front & rear axles
Hydraulics		
Hydraulic pump type		Gear pump
Hydraulic flow / Pressure		125 l/min / 270 Bar
Tank capacities		
Engine oil		10 l
Hydraulic oil		140 l
Fuel tank		120 l
DEF tank capacity		22.60 l
Noise and vibration		
Noise at driving position (LpA)		77 dB(A)
Noise to environment (LWA)		103 dB(A)
Vibration on hands/arms		< 2.5 m/s
Miscellaneous		
Steering wheels (front / rear)		2 / 2
Drive wheels (front / rear)		2 / 2
Safety / Safety cab homologation		Standard EN 15000 / Cab ROPS - FOPS Level 2
Controls		JSM

Dimensional drawing

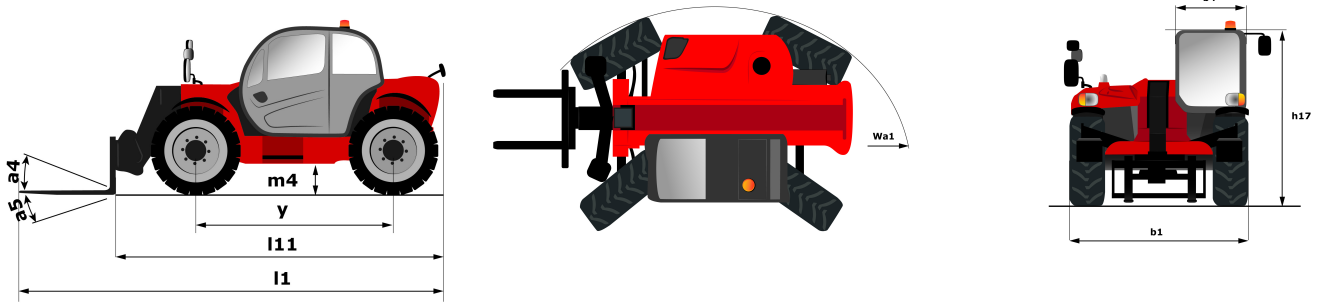

Load chart

Machine on stabilizers with forks Metric

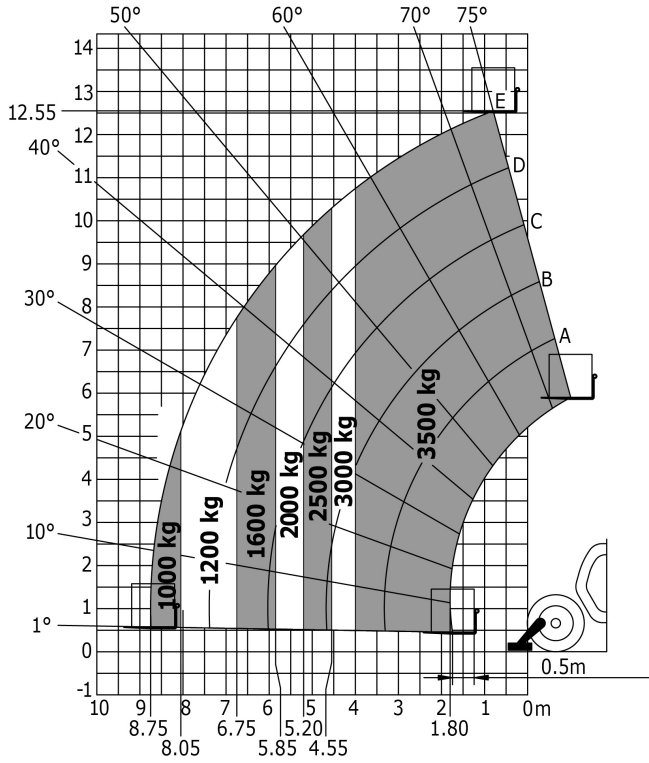

Machine on tyres with forks Metric

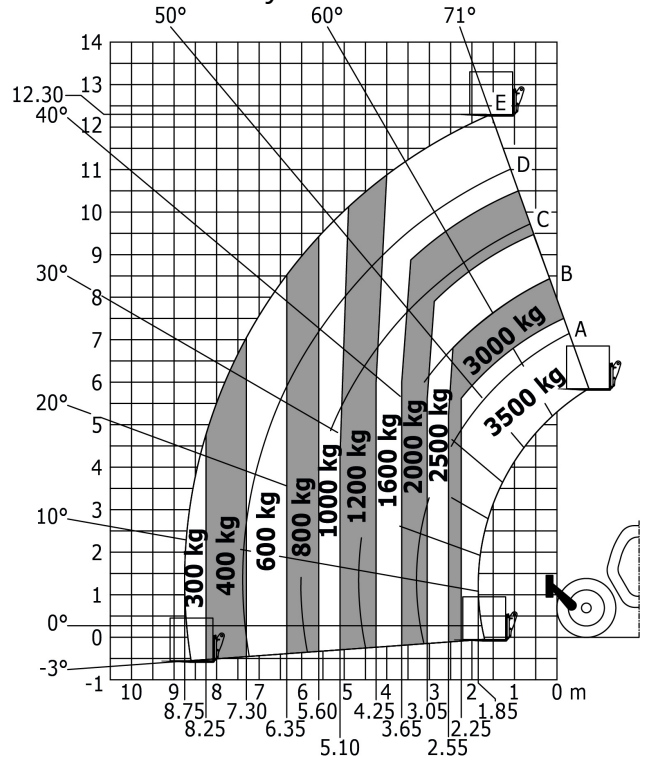



Siège Social

430 rue de l'Aubinière - 44150 Ancenis Cedex - France

Tel: +33(0)2 40 09 10 11 - Fax: +33 (0)2 40 09 10 97

www.manitou.com



This brochure describes versions and configuration options for Manitou products which may be fitted with different equipment. The equipment described in this brochure may be standard, optional or not available depending on version. Manitou reserves the right to change the specifications shown and described at any time and without prior warning. The manufacturer is not liable for the specifications given. For more information, contact your Manitou dealer. Non-contractual document. Product descriptions may differ from actual products. List of specifications is not comprehensive. The logos and visual identity of the company are the property of Manitou and may not be used without authorisation. All rights reserved. The photos and diagrams contained in this brochure are provided for information only.

MANITOU BF SA - Limited company with board of directors - Share capital: 39,668,399 euros - 857 802 508
RCS Nantes